

R-Series Models RP and RH Sensors DeviceNet Output



- Rugged industrial sensor
- Linear, absolute measurement
- LEDs for sensor diagnostics
- Non-contact sensing technology
- Superior accuracy, resolution down to 2 μm
- Non-linearity less than 0.01%
- Repeatability within 0.001%
- Direct DeviceNet output

Controller Area Network (CAN) is a standard for device level communications and the foundation of fieldbus systems like DeviceNet, CANopen and CANbus. These fieldbus systems can provide high speed transmission appropriate for position indication and for motion control in industrial applications.

DeviceNet allows users to interface up to 64 devices using a single cable, thus eliminating the need for conventional methods of multiple wire runs. DeviceNet provides a way to define how, and in which priority, data will be transmitted over the network. The result is a lower complexity, cost-effective communications network linking industrial measurement and control devices. Together, the open DeviceNet protocol and the MTS “smart” R-Series sensors offer an effective, high-precision data transfer system that is well suited for industrial automation.

Parameters	Specifications
Measured variable:	Displacement
Resolution:	2 μm or 5 μm
Non-linearity:	$< \pm 0.01\%$ full scale (minimum $\pm 40 \mu\text{m}$)
Repeatability:	$< \pm 0.001\%$ full scale (minimum $\pm 2.5 \mu\text{m}$) Hysteresis $< 4 \mu\text{m}$
Output:	Interface: CAN-Fieldbus system ISO 11898 Data protocol: DeviceNet release 2.0 Baud rate, kBit/s: 500 250 125 Cable length, m: <100 <250 <500 The sensor will be supplied with ordered Baud rate which can be changed by the customer.
Stroke length:	Profile style: 50 mm (2 in.) to 5080 mm (200 in.) Rod style: 50 mm (2 in.) to 7620 mm (300 in.)

Parameters	Specifications (continued)
Operating voltage:	+24 Vdc nominal: -15% or +20% Polarity protection: up to -30 Vdc Overvoltage protection: up to 36 Vdc Current drain: 90 mA typical Dielectric withstand voltage: 500 Vdc (DC ground to machine ground) Connection type: 5-pin male D51 DeviceNet connector
Operating temperature:	-40 $^{\circ}\text{C}$ (-40 $^{\circ}\text{F}$) to 75 $^{\circ}\text{C}$ (167 $^{\circ}\text{F}$) Relative humidity: 90% no condensation Temperature coefficient <15 ppm/ $^{\circ}\text{C}$
EMC test:	Emissions IEC/EN 50081-1, Immunity IEC/EN 50082-2, IEC/EN 61000-4-2/3/4/6, level 3/4 criterion A, CE qualified
Shock rating:	100 g (single hit)/IEC standard 68-2-27 (survivability)
Vibration rating:	15 g (30 g with HVR option)/ 10-2000 Hz/IEC standard 68-2-6
Update time:	0.5 ms up to 1200 mm, 1.0 ms up to 2400 mm, 2.0 ms up to 4800 mm, 4.0 ms up to 7600 mm stroke length

PROFILE STYLE (MODEL RP) SENSOR

Electronic head:	Aluminum housing Diagnostic display (LED's located beside connector)
Sealing:	IP 65
Sensor extrusion:	Aluminum
Mounting:	Adjustable mounting feet or T-slot nut (M5 threads) in base channel
Magnet type:	Captive-sliding magnet or open-ring magnet

ROD STYLE (MODEL RH) SENSOR

Electronic head:	Aluminum housing Diagnostic display (LEDs located beside connector)
Sealing:	IP 67
Sensor rod with flange:	304L Stainless steel
Operating pressure:	350 bar static, 690 bar spike (5000 psi static; 10,000 psi spike)
Mounting:	Threaded flange M18 x 1.5 or 3/4-16 UNF-3A
Typical mounting torque:	45 N-m (33 ft. - lbs.)
Magnet type:	Ring magnet, open-ring magnet, or magnet float



DEVICENET OUTPUT

DeviceNet protocol

R-Series models RP and RH linear-position sensors as slave devices fulfill all requirements of the CANbus (ISO 11898) standard. The sensors electronics and integrated software implement the DeviceNet protocol to convert the displacement measurements into bus oriented outputs and transfer this data directly to the controller. The DeviceNet protocol is appropriate for serial data transfer up to 500 kBit/sec.

When using the DeviceNet protocol with R-series models RP and sensors, functionality always includes but is not limited to the following:

- Position
- Error Detection
- Polling & bit-strobe communications modes

Plug and play

R-Series sensors with DeviceNet output can be directly connected to a DeviceNet network. The plug and play design makes installation quick and easy. The sensor acts as a “slave” device that transmits its position and status data upon request to the “master” device such as a PLC or IPC. After initial system configuration, the user is not required to have extensive knowledge concerning network timing and sensor technology to execute operations within DeviceNet environment. Sensor-specific parameters are installed into the network using the Electronic Data Sheet (EDS). To obtain the EDS, go to www.mtssensors.com.

There are only two programmable parameters, which are, the node identifier and the baud rate. If desired, a PC programming tool, such as DeviceNet Manager offered by Allen Bradley, can be used to change their values. The node identifier is factory set at node 63.

Enhanced monitoring and diagnostics

Bi-color LEDs in the cover of the sensor head provide visual feedback for normal sensor operation and for DeviceNet communications.

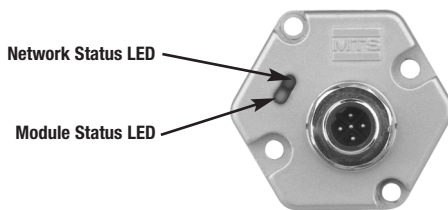

Network Status LED

Green	Normal function
Green flashing	Waiting for instructions from DeviceNet master.
Red	Initialing error
Red flashing	No answer from DeviceNet master

Module Status LED

green	Normal function
Red	Magnet not detected

CONNECTIONS AND WIRING

Cable connectors (field-installed female micro DeviceNet)

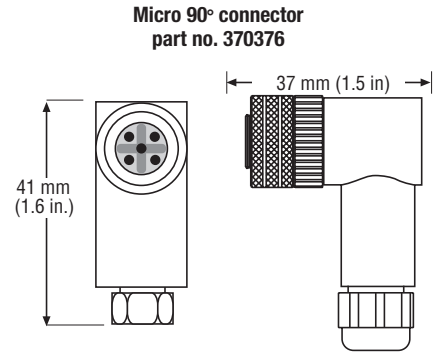

Micro straight-exit connector
part no. 370375

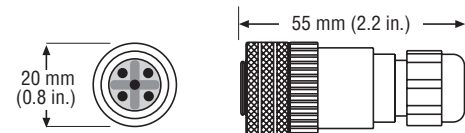

Notes:

1. Appropriate grounding of cable shield is required at the controller end.
2. Molded extension cables are available from third-party vendors.

Sensor integral connector 5-pin (D51) male

Wiring

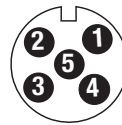

Pin no.	Function
1	Shield
2	+24 Vdc (+20% / -15%)
3	DC Ground (for supply)
4	CAN (+)
5	CAN (-)

Male D51 connector pin-out as viewed from the end of the sensor.

MODEL RP PROFILE-STYLE SENSOR

Captive-sliding magnet

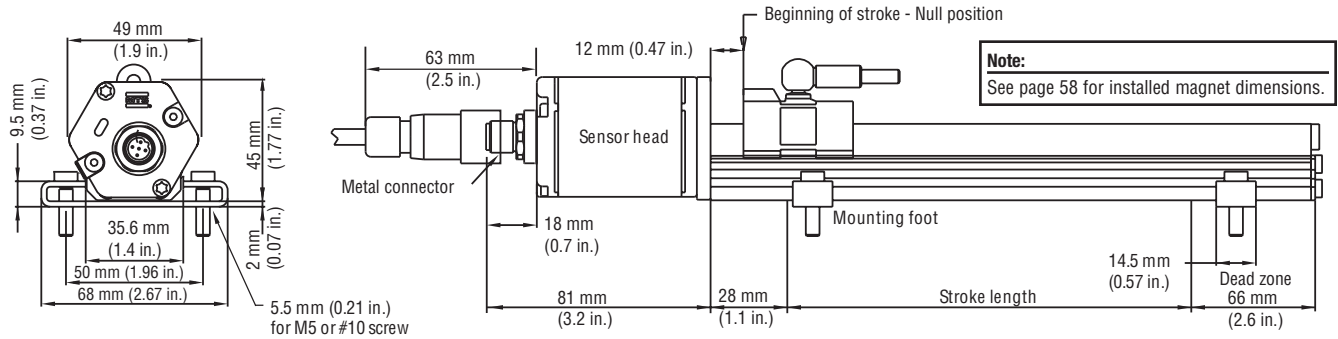

Open-ring magnet

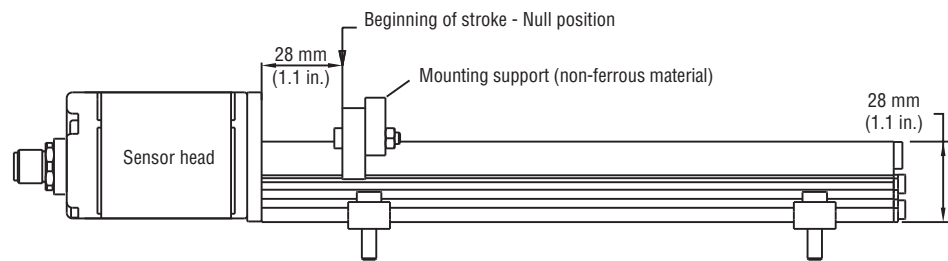

MODEL RH ROD-STYLE SENSOR

The rod-style (Model RH) sensor offers modular construction, flexible mounting configurations, and easy installation. It is designed for internal mounting in applications where high pressure conditions exist, (5000 psi continuous, 10,000 psi spike), such as hydraulic cylinders. The Model RH sensor may also be mounted externally in many applications.

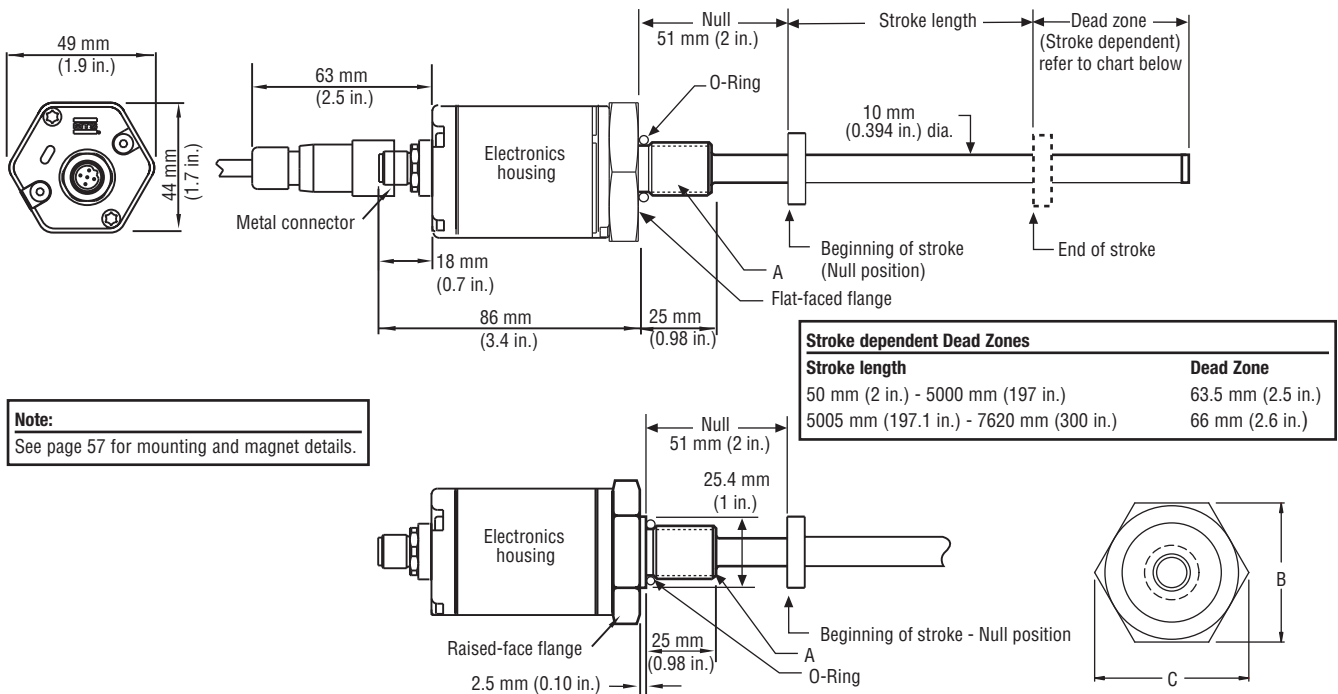

Housing style Flange type	Description	A Flange threads	B Dimensions	C Dimensions
T	US customary threads with raised-face flange	3/4"-16 UNF-3A	44.5 mm (1.75 in.)	51 mm (2 in.)
S	US customary threads with flat-faced flange	3/4"-16 UNF-3A	44.5 mm (1.75 in.)	51 mm (2 in.)
M	Metric threads with flat-faced flange	M18 x 1.5	46 mm (1.81 in.)	53 mm (2.1 in.)

HOW TO ORDER

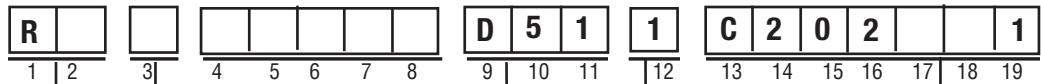

SENSOR MODEL

- RP** = Profile style
- RH** = Hydraulic rod-style
- RF** = Flexible style

HOUSING STYLE

Model RP profile-style sensor only (magnet included):

- S** = Captive-sliding magnet with joint at top (part no. 252182)
- V** = Captive-sliding magnet with joint at front (part no. 252184)
- M** = Open-ring magnet (part no. 251416-2)

Model RH rod-style sensor only (magnet must be ordered separately):

- T** = US customary threads, raised-faced flange and pressure tube, standard
- S** = US customary threads, flat-faced flange and pressure tube, standard
- U** = Same as option "T", except uses fluoroelastomer seals for electronics housing
- H** = Same as option "S", except uses fluoroelastomer seals for electronics housing
- M** = Metric threads, flat-faced flange and pressure tube, standard
- V** = Same as option "M", except uses fluoroelastomer seals for electronics housing
- B** = Sensor cartridge only (no flange and pressure tube, stroke length < 1830 mm (72 in.))

Model RF flex sensor only, (reference page 41 for flex housing style):

magnet must be ordered separately:

- S** = US customary threads, flat-faced flange
- M** = Metric threads, flat-faced flange

STROKE LENGTH

- **M** = Millimeters (Encode in 5 mm increments)
- **U** = Inches and tenths (Encode in 0.1 in. increments)

Stroke length notes:

1. Profile-style sensor (model RP) stroke length = 50 mm (2 in.) - 5080 mm (200 in.)
2. Rod-style sensor (model RH) stroke length = 50 mm (2 in.) - 7620 mm (300 in.)

CONNECTION TYPE

Integral connector:

- D51** = 5-pin Micro DeviceNet, male, standard

INPUT VOLTAGE

- 1** = +24 Vdc (+20% - 15%)
- A** = Same as option "1", except includes the High Vibration-Resistant (HVR) option
Model RH sensor only, stroke length = 50 mm (2 in.) - 2000 mm (78.7 in.) see note

Note:

The High Vibration-Resistant (HVR) option provides the model RH rod-style sensors with increased resistance to shock and vibration for use in heavy duty machinery. Refer to "G-Series and R-Series Sensors for High Shock and Vibration Applications", part no. 551073 for more information.

OUTPUT

- C** _____ = CANbus output w/DeviceNet Protocol (Fill in the six blanks with the following codes:
a b c d e f

- | | | | | |
|---------------------|-------------------------------------|------------------------|-------------------------------|----------------------|
| a) Hardware | b,c) DeviceNet Protocol code | d) Baud rate | e) Resolution | f) Cycle time |
| 2 = Standard | 02 = DeviceNet | 2 = 500 kBits/s | 1 = 5 μm (0.0002 in.) | 1 = Standard |
| | | 3 = 250 kBits/s | 2 = 2 μm (0.00008 in.) | |
| | | 4 = 125 kBits/s | | |

DeviceNet EDS files are available on the Temposonics website at www.mtsensors.com